



MANUFACTURER

HALLDE

MODEL

RG-300i

PRODUCT DESCRIPTION

Vegetable Preparation Machine, process up to 40 kg/minute.

ORIGIN

Sweden

SPECIFIKATION

SPECIFICATION TEXT	Floor standing Vegetable Preparation Machine with a full moon, 5,7 litre Feed Cylinder, made to process up to 2.4 tons/ hour or up to 3 000 portions/day. Feed Cylinders, Feeders and Cutting Tools made of stainless steel, can be cleaned in a dishwasher machine. The machine has one speed, 400 rpm. The legs of the machine have two adjustable feet and two feet with wheels. Cutting tools made of stainless steel/ aluminum with removable knives/plates, 215 mm in diameter. The motor with the maintenance free planetary gearing, rotates clock wise.			
FUNCTION	Machine for slicing, dicing, shredding, grating, cutting julienne, crimping slicer and potato chips. Processes fruit, vegetables, dry bread, cheese, nuts, mushrooms, etc.			
CAPACITY	Up to 3 000 portions/day, and up to 2.4 tons/ hour (40 kg/ min). Feed cylinder volume: 5.7 litre. Manual feeder with built-in tube feeder, diameter 60 mm. Feed Hopper: volume approx. 23 litre. 4-tube Insert with four tubes: diameter 73 mm (2 tubes), 60 mm and 35 mm.			
MATERIAL	Machine base, Feed cylinders and feeders: Stainless steel. Cutting tools discs: Stainless steel/ Aluminum. Cutting tool knife blades: Stainless knife steel.			
MOTOR	0.75 kW. One-speed (400 rpm)380-415 V, 3-fas, 50-60 Hz. Thermal protection, maintenance free gear drive.			
POWER SUPPLY	Earthed, three phase.			
STANDARDS	EN 1678+A1:2010. NSF/ANSI Standard 8.			
RECOMMENDED PACKAGES	CONTENT	NET WEIGHT	STANDARD PACK	FULL FLEX
	• RG-300i Manual Feeder / 380-415 3N 50/60	49 kg	X	X
	• 4-Tube insert incl. 2 pestles	5 kg	X	X
	• Feed Hopper incl. cylinder	11 kg		X
	• Container trolley incl. GN 1/1 container	9 kg	X	X
	• Basin Trolley, 85 litres	15 kg	X	X
	• Accessory Trolley, stainless steel with lockable wheels	17 kg	X	X
	• Container Trolley Low, 2x7 GN 1/1	19 kg		X
	• 6-pack Cutting Tools – Slicer 1.5 mm – Grater/Shredder 4.5 mm – Slicer 4 mm – Dicing Grid 10x10 mm – Slicer 6 mm – Slicer 10 mm	6 kg	X	
• 9-pack Cutting Tools – Slicer 1.5 mm – Grater/Shredder 2 mm – Slicer 4 mm – Grater/Shredder 8 mm – Slicer 6 mm – Fine Grater – Slicer 10 mm – Dicing Grid 10x10 mm – Julienne Cutter 4x4 mm	9 kg		X	
WEIGHT/VOLUME	CONTENT	PACKAGES	FREIGHT WEIGHT	FREIGHT VOLUME
	Standard Pack excl. Container- and Accessories Trolley	1 pallet	106 kg	1.60 m ³
	Full Flex excl. Container- and Accessories Trolley	1 pallet	150 kg	1.96 m ³
	Container Trolley incl. GN 1/1 container	1	12.5 kg	0.15 m ³
	Accessory Trolley Stainless steel	1	30 kg	0.63 m ³
SAFETY	2014/30/EU, 2014/35/EU, 2006/42/EG, 2011/65/EU, no 10/2011, 1935/2004CE, SS-EN ISO 26800:2011.			

DIRECTIVE AND REGULATION

CE approved. Three safety switches, machine safety: IP44, push buttons safety: IP65.

DRAWINGS

The drawings below can be downloaded at hallde.com.

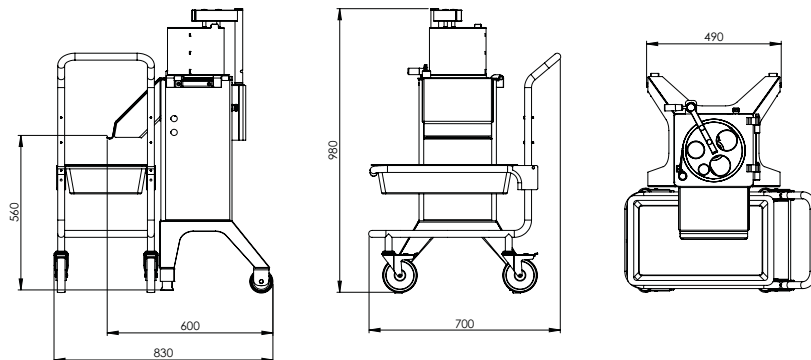
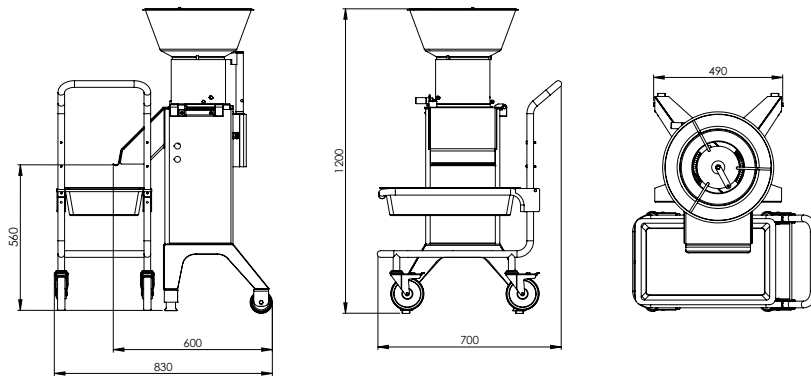
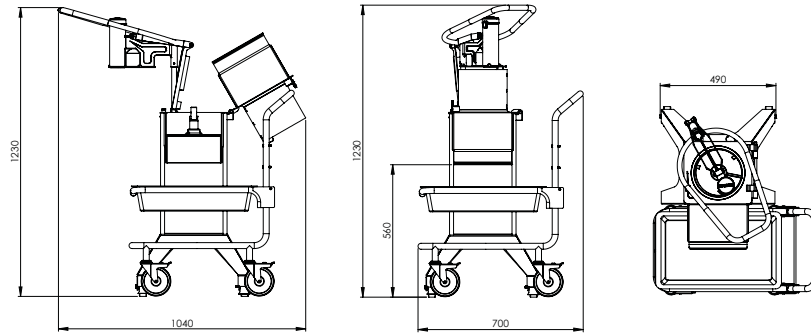

Recommended working area around the machine:

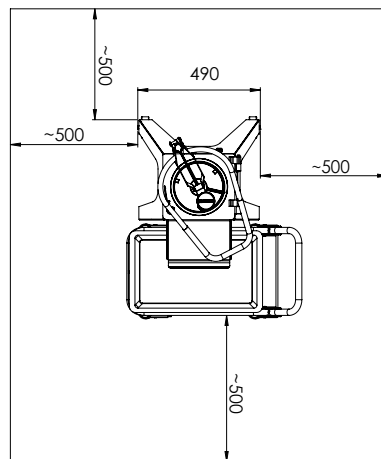

Accessories Trolley:

